

# Truck range



worldwide network

24/7  
support



Meet the UniCarriers family

# With the DNA for maximum uptime

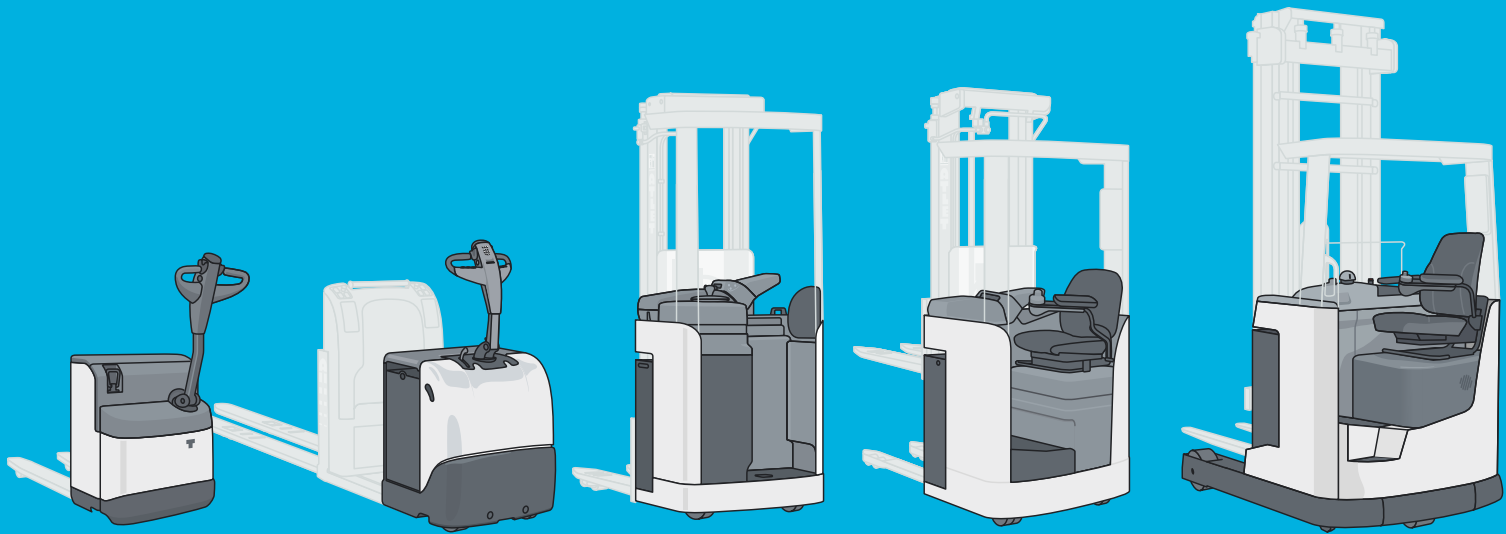



UniCarriers designs, manufactures and supports the most advanced material handling equipment. By integrating the three distinctive brands of Atlet, Nissan Forklift and TCM, UniCarriers is the perfect mixture of Japanese quality and technology, Swedish design and ergonomics and German innovative spirit for the material handling industry. UniCarriers represents more than 65 years of industry experience, an unparalleled global reach and deep understanding of local markets.

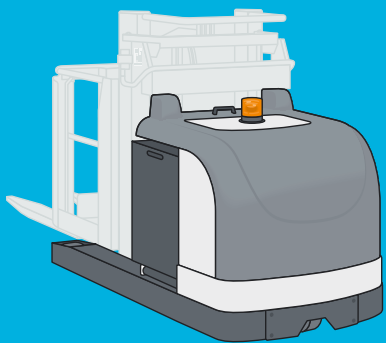

Flexibility and reliability are essential to survive and prosper in today's business environment. And nowhere is this more evident than in the material handling industry. That's why we at UniCarriers have pioneered a unique product concept that increases reliability through component flexibility and modularisation. Thanks to this, we can offer thousands of customised UniCarriers truck variants – each one built with exceptional technical and ergonomic standards for your specialised tasks – with interchangeable components. This concept also allows us to minimise the number of parts and components, which is one of the reasons behind UniCarriers' superior after-sales service. By only having to deal with a limited number of components, our mobile service engineers can fix over 95% of all breakdowns – on the first visit. UniCarriers engineering simply translates into less downtime and more uptime. And that can mean a lot for your business.

## Pallet trucks

### PLL Compact pedestrian pallet truck

Lift capacity 1450/1800/2000 kg



### PLE Compact pedestrian pallet truck with forklift

Lift capacity 1800 kg  
Lift height 0.73 metres



### PLP Stand-on pallet truck

Lift capacity 2000/2500 kg



### ERGO ALL/XLL Stand-in and sit-on low lifters

Lift capacity 2000/3000 kg



## Stackers

### SOLO PSL Compact pedestrian stacker

Lift capacity 1250 kg  
Lift height up to 2.1 metres

### PS Compact pedestrian stacker

Lift capacity 1250 kg  
Lift height up to 4.2 metres

### PSH

Lift capacity 1600/2000 kg  
Lift height up to 5.4 metres

### PSP Pedestrian stacker

Lift capacity 1250/1600 kg  
Lift height up to 5.4 metres

### PSD Compact pedestrian stacker for double-pallet handling

Lift capacity 1250/1600 kg  
on the straddles  
Lift height up to 2.1 metres



**PDP 200**  
Double stacker  
with platform

Lift capacity 2000 kg  
Lift height 2.1 metres



**ERGO A**  
Stand-in stacker

Lift capacity 1600/2000 kg  
Lift height up to 6.75 metres



**ERGO X**  
Sit-on stacker

Lift capacity 1600/2000 kg  
Lift heights up to 6.75 metres



**ERGO XML**  
Sit-on double stacker

Lift capacity 1600 kg  
Lift height 1.5 metres



**ERGO ATF/XTF**  
Telereach stacker  
stand-in and sit-on  
telescopic forks

Lift capacity 1000 kg  
Lift height up to 6.75 metres

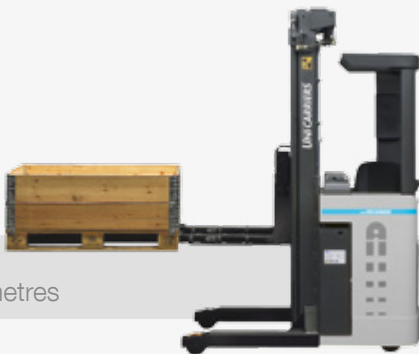

Order pickers

**PP**  
Low-level order picker

**PPL**

Lift capacity 2000/2500 kg

**PPD**

Lift capacity 2000/2500 kg



**PPF**

Lift capacity 1200 kg  
Lift height 0.95 metres

**PPC**

Lift capacity 1200 kg  
Lift height 0.95 metres



**PPS**

Lift capacity 2000 kg  
Lift height 0.9 metres

**OP**  
High-level order picker

**OPM**

Lift capacity 1000 kg  
Lift height up to 2.9 metres

**OPH**

Lift capacity 1000 kg  
Lift height up to 5.3 metres

**OPC**

Lift capacity 1000 kg  
Lift height up to 6.2 metres

**OPS**

Lift capacity 1000 kg  
Lift height up to 8.25 metres



## Reach trucks

### TERGO® ULS Narrow-chassis reach truck

Lift capacity 1200/1400 kg  
Lift height up to 7.25 metres



### TERGO® UND Narrow-chassis reach truck

Lift capacity 1400 kg  
Lift height up to 8.95 metres



### TERGO® UMS/UHD/UHX Reach truck

Lift capacity 1600/2000/2500 kg  
Lift height up to 12.1 metres



### TERGO® UMS-TF/UHD-TF/UHX-TF Reach truck with telescopic forks

Lift capacity 2000/2500 kg  
Lift height up to 12.1 metres

### TERGO® UFW Four-way reach truck

Lift capacity 2000/2500 kg  
Lift height up to 9.7 metres



## Very narrow aisle reach trucks

### TERGO® URS Swivel reach truck

Lift capacity 1250/1500 kg  
Lift height up to 10.35 metres



## Electric counterbalance forklift trucks

The TX3/TX4/QX2 electric counterbalance trucks are silent, easy to drive and efficient. They have top-class ergonomics with a fully adjustable driver compartment. An on-board truck computer offers PIN-code-access and service diagnostics. AC drive motor ensures high class performance and low running costs. The counterbalance truck range comes with a full range of mast systems and an efficient battery changeover system.

### TX3 3-wheel counterbalance truck

Lift capacity 1250/1500/1600/  
1750/1800/2000 kg  
Lift height up to 7 metres



### TX4 4-wheel counterbalance truck

Lift capacity 1600/1800/2000 kg  
Lift height up to 7 metres



### QX2 4-wheel counterbalance truck

Lift capacity 2000/2500/3000 kg  
Lift height up to 7 metres



### BX 4-wheel counterbalance truck

Lift capacity 1500–2500 kg  
Battery capacity 48 volts



## Diesel/LPG counterbalance forklift trucks

The D/G internal combustion (Diesel/LPG) counterbalance trucks with car-like driveability – featuring advanced safety and efficiency-enhancing technology. The meter panel provides on-board diagnostics for troubleshooting.

### DX 4-wheel IC counterbalance truck

Lift capacity 1500/1800/2000/2500/  
3000/3200 kg  
Lift height up to 7 metres



### GX 4-wheel IC counterbalance truck

Lift capacity 3500/4000/4500/  
5000 kg  
Lift height up to 7 metres



### LX 4-wheel counterbalance truck

Lift capacity 1500–3600 kg,  
compact cushion, LPG/  
1600–2500 kg,  
compact pneumatic,  
gasoline & LPG dual fuel



### LX35

Lift capacity 3500 kg, gasoline, Diesel & LPG

### ZX 4-wheel counterbalance truck

Lift capacity 6000/7000/8000/  
10000 kg



It's all about  
the price.  
**But what  
price?**

## Reduce your Total Cost of Operation with UniCarriers

We agree. Price is everything. Or to be more specific: your Total Cost of Operation (TCO). That's why we're so focused on cutting costs and improving your material handling. The truck and its performance play an important role, but this is even more about how we can support you in optimising your warehouse operations to give you the best value for your money. Which – in the long run – is what creates a winner.



ClimatePartner<sup>o</sup>  
**climate neutral**

Print | ID: 10767-1410-1003

**UNICARRIERS CORPORATION**  
**U-TR.EN/UCE-2014-10 Printed in Germany**

UniCarriers Corporation reserves the right to make any changes without notice concerning colours, equipment or specifications detailed in this brochure, or to discontinue individual models. The colours of vehicles delivered may differ slightly from those in this brochure. The specifications vary for different countries depending on local market conditions. Please consult your local dealer to ensure that the vehicle delivered accords with your expectations. All values are determined based on the standard condition and may vary due to motor and system tolerances, condition of the truck and operational conditions. Some equipment shown on photos is optional.